



DIN Connectors

 **ravioli**™ 

90th
Years of experience

Twin connectors

Europe Series 80-160-320 A

Manufactured by Ravioli since 1981, these connectors are suitable for linking motors, batteries, battery chargers for lifting trucks, aerial platforms, sweepers, scrubbers and other electrical vehicles for industry.

They are in accordance with the current Norms DIN VDE 0623-589, which define unified distances between centres and unified coupling dimensions and which currently represent the evolution of the previous DIN Norms 43589 – part 1 and 2 - and FEM 4007a and 4007b.

Approval **CE ENEC**

Each model is made up of a plug and a socket, different from each other, and both prepared for a fitting for a handle.

Thanks to our engineers' expert work, through the years our customers have well accepted the easy assembly and the intuitive use of our connectors, as well as the considerable saving of time for their wiring, since the number of their components is limited.

Thanks to several technical features, our connectors are considerably robust, resistant and suitable for various applications, maintaining the same quality standards through the time.

The range 80-160-320 A includes two versions:

- Shock resistant housing
For all applications requiring robustness and high resistance against shocks;
- Innovative, acid-proof polymer housing:
For all applications requiring high resistance against acid.

All electrical parts are protected against accidental contact.

Standard equipment includes a balanced cable clamp , ensuring IP23 to the final coupled connectors.

The main contacts are silver-plated, electrolytic copper against corrosion, ensuring the best crimping with the correct assembly.

- Maximum operative voltage: 150 Vdc
- Temperature range: -20°C +90°C
- DIN 80: current capacity 80 A with 25 sqmm. section cable
- DIN 160: current capacity 160 A with 50 sqmm. section cable
- DIN 320: current capacity 320 A with 95 sqmm. section cable



Twin connectors

Europe Series 80-160-320 A

The connectors are supplied with a coding pin for operative voltage which ensures that only same voltage plugs and sockets will be connected.

Codified values are V 24-36-48-72-80-96,

There are three different types of pins:

grey coding pin: for wet batteries

yellow coding pin: universal

green coding pin: for dry or gel batteries.

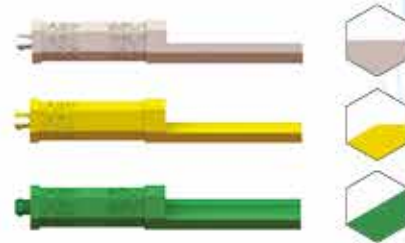

Serial equipment includes reduction bushings for an easier wiring, with different cable sections, decreasing thus the customers' operating costs:

80 A: bushing from 25 mm² to 16 mm²

160 A: bushing from 50 mm² to 35 mm²

320 A: bushing from 70 mm² to 50 mm²

Optional reduction bushings are also available on request:

160 A: bushing from 50 mm² to 25 mm²

320 A: bushing from 70 mm² to 35 mm²



The declared currents refer to the max. current capacity at environment temperature (max. 40°C) with the biggest allowed cable section. If using smaller sections, please contact our company.

As accessories for both plugs and sockets, you can additionally mount even 4 auxiliaries, 2 primary and 2 secondary, featuring maximum 20 A continuous duty with advance opening in comparison to the main contacts. Cables with section 2,5 mm² are recommended to be used with the auxiliaries.



Secondary auxiliary contacts

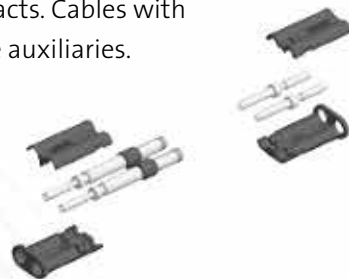

Primary auxiliary contacts

Furthermore, where it is necessary to mix the batteries electrolyte in the cells through air, you can mount a pair of air tubes into our connectors, in alternative to the primary auxiliary contacts, letting the air in through a 6 mm. or 8 mm. internal diameter tube.



Connectors Europe Series

DIN 80 A

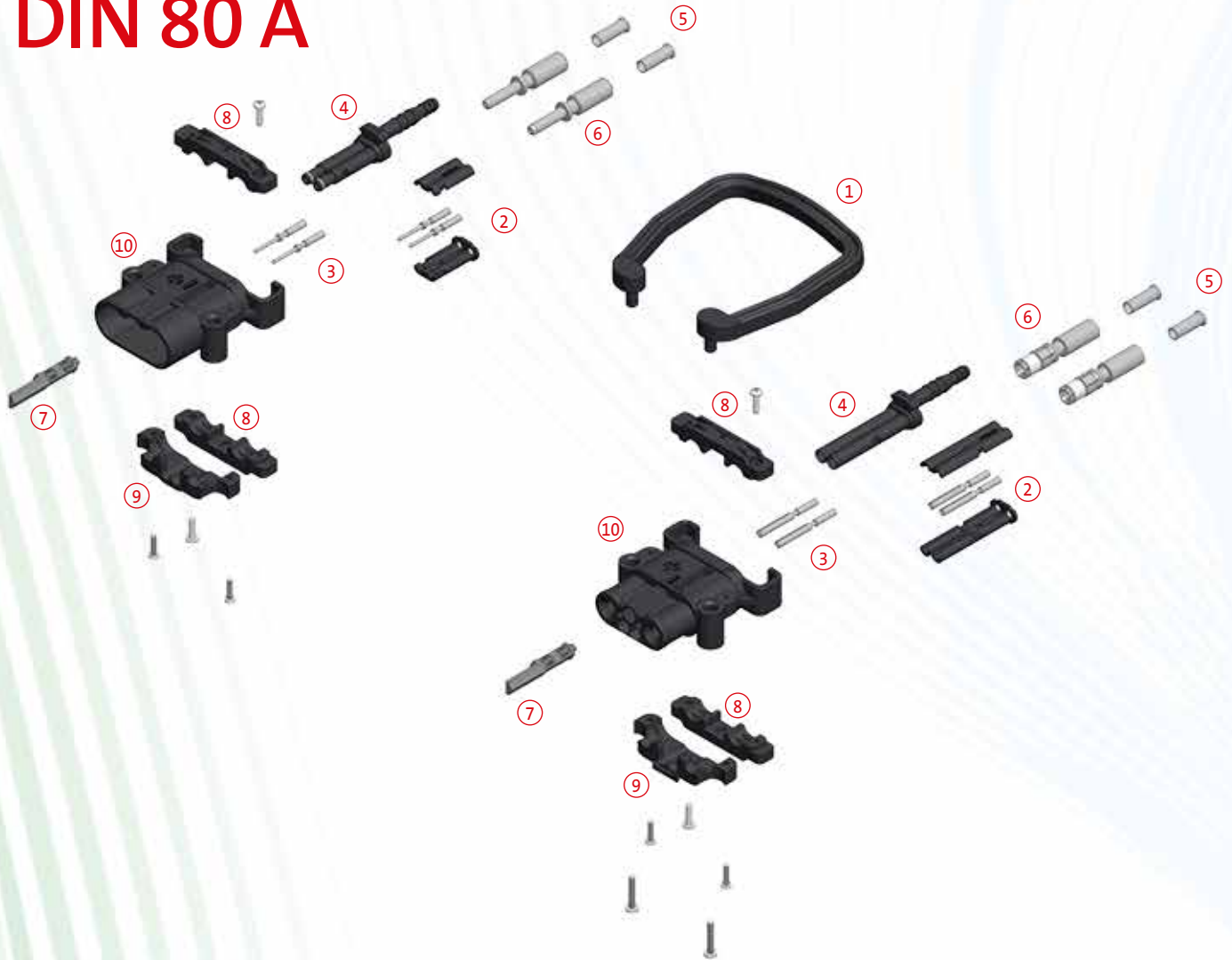

Accessories

①	EMAN80ST	Shock resistant handle 80 A
	EMAN80AR	Acid-proof handle 80 A
	EXS80PRST	2 primary Aux. Contacts for plug 80 A
②	EXP80PRST	2 primary Aux. Contacts for socket 80 A
	EXS80PRAR	2 primary Aux. Contacts for acid-proof plug 80 A
	EXP80PRAR	2 primary Aux. Contacts for acid-proof socket 80 A
	EXS80SEC	2 secondary Aux. Contacts for plug 80 A
③	EXP80SEC	2 secondary Aux. Contacts for socket 80 A
	EAIRTUBE80S	Air tube for plug 80 A
④	EAIRTUBE80P	Air tube for socket 80 A

Spare parts

⑥	EGPP-S80	2 Main Contacts for plug 80 A
	EGPP-P80	2 Main Contacts for socket 80 A
	E34404	Grey coding pin 80 A
⑦	E34435	Yellow coding pin 80 A
	E34434	Green coding pin 80 A

Part numbers

Part numbers are so composed:

XXXX 80 XX X

ESBC = plug
 EPBC = socket
 EKPM = socket + handle
 ST=shock resistant
 AR=Acid-proof

Add "KIT" at the end of the part number to order the set including 100 not bagged pieces.

- 1 = grey coding pin for wet batteries
- 2 = yellow universal coding pin
- 3 = green pin for dry or gel batteries

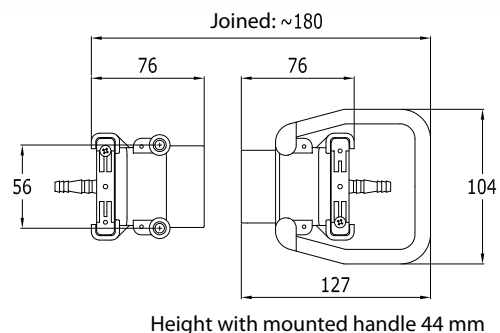

Connectors Europe Series

DIN 160 A

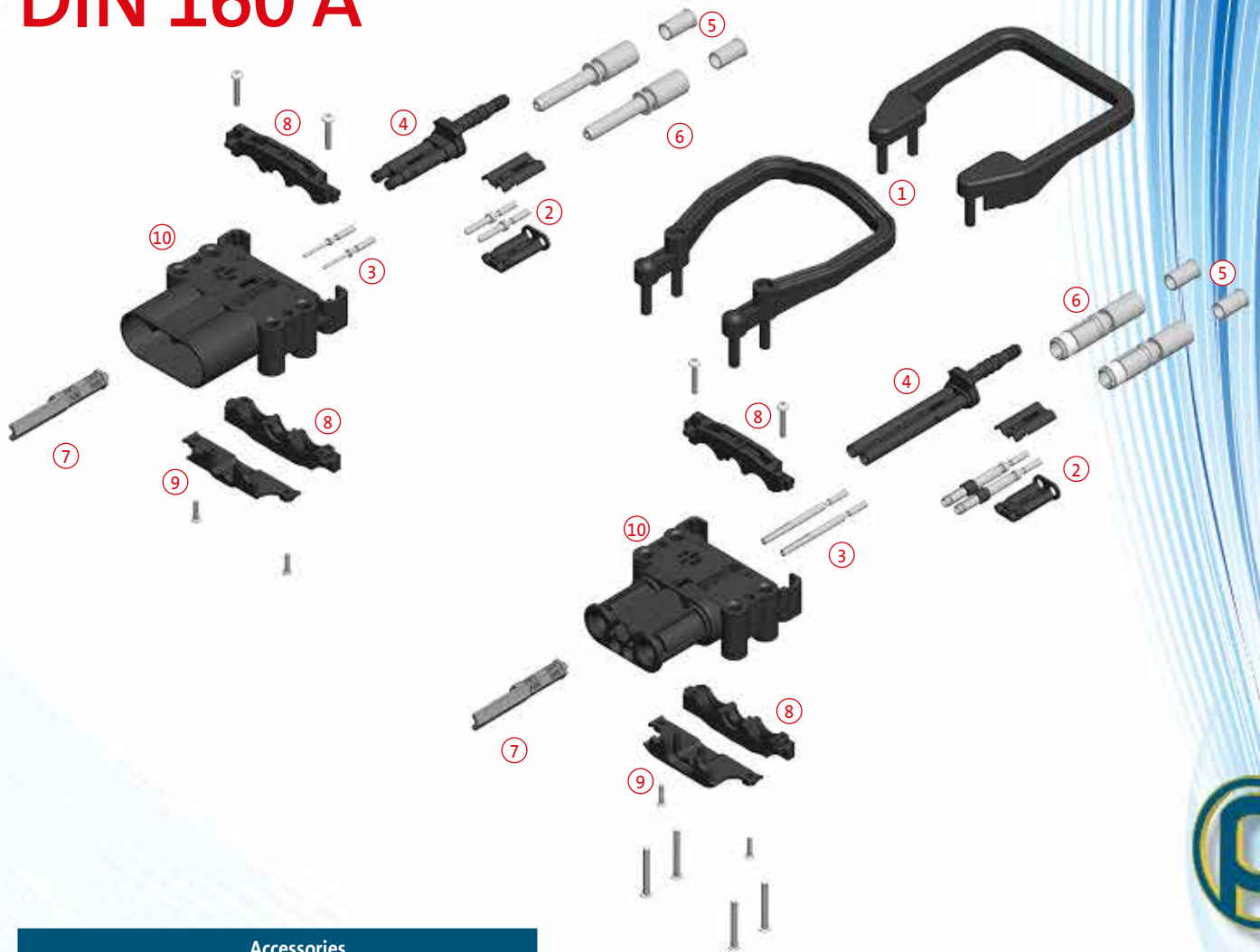

Accessories

	EM160320ST	Shock resistant handle 160/320 A
①	EM160320AR	Acid-proof handle 160/320 A
	EM160320STP	Shock resistant flat handle 160/320 A
	EM160320ARP	Acid-proof flat handle 160/320 A
	EXS160320PRST	2 primary Aux. Contacts for plug 160/320 A
②	EXP160320PRST	2 primary Aux. Contacts for socket 160/320 A
	EXS160320PRAR	2 primary Aux. Contacts for acid-proof plug 160/320 A
	EXP160320PRAR	2 primary Aux. Contacts for acid-proof socket 160/320 A
③	EXS1605SEC	2 secondary Aux. Contacts for plug 160/320 A
	EXP1605SEC	2 secondary Aux. Contacts for socket 160/320 A
④	EAIRTUBE160S	Air tube for plug 160/320 A
	EAIRTUBE160P	Air tube for socket 160/320 A
⑤	ERID50-25	Reduction bushing 50-25mm ²

Spare parts

⑥	EGPP-S160	2 Main Contacts for plug 160/320 A
	EGPP-P160	2 Main Contacts for socket 160/320 A
	E29304	Grey coding pin 160/320 A
⑦	E29367	Yellow coding pin 160/320 A
	E29366	Green coding pin 160/320 A

Part numbers

Part numbers are so composed:

XXXX 160 XX X

ESBC = plug
 EPBC = socket
 EKPM = socket + handle
 ST=shock resistant
 AR=Acid-proof

Add "KIT" at the end of the part number to order the set including 100 not bagged pieces.

1 = grey coding pin for wet batteries
 2 = yellow universal coding pin
 3 = green pin for dry or gel batteries

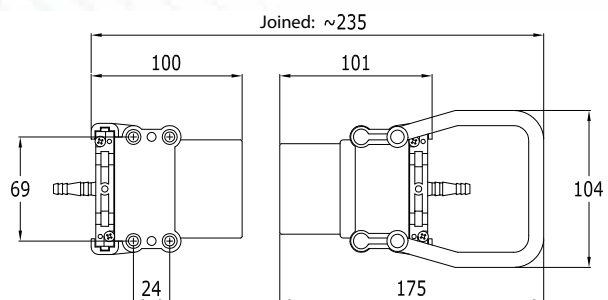

Height with mounted standard handle: 57 mm.
 Height with mounted flat handle: 40,5 mm.

DIN 320 A

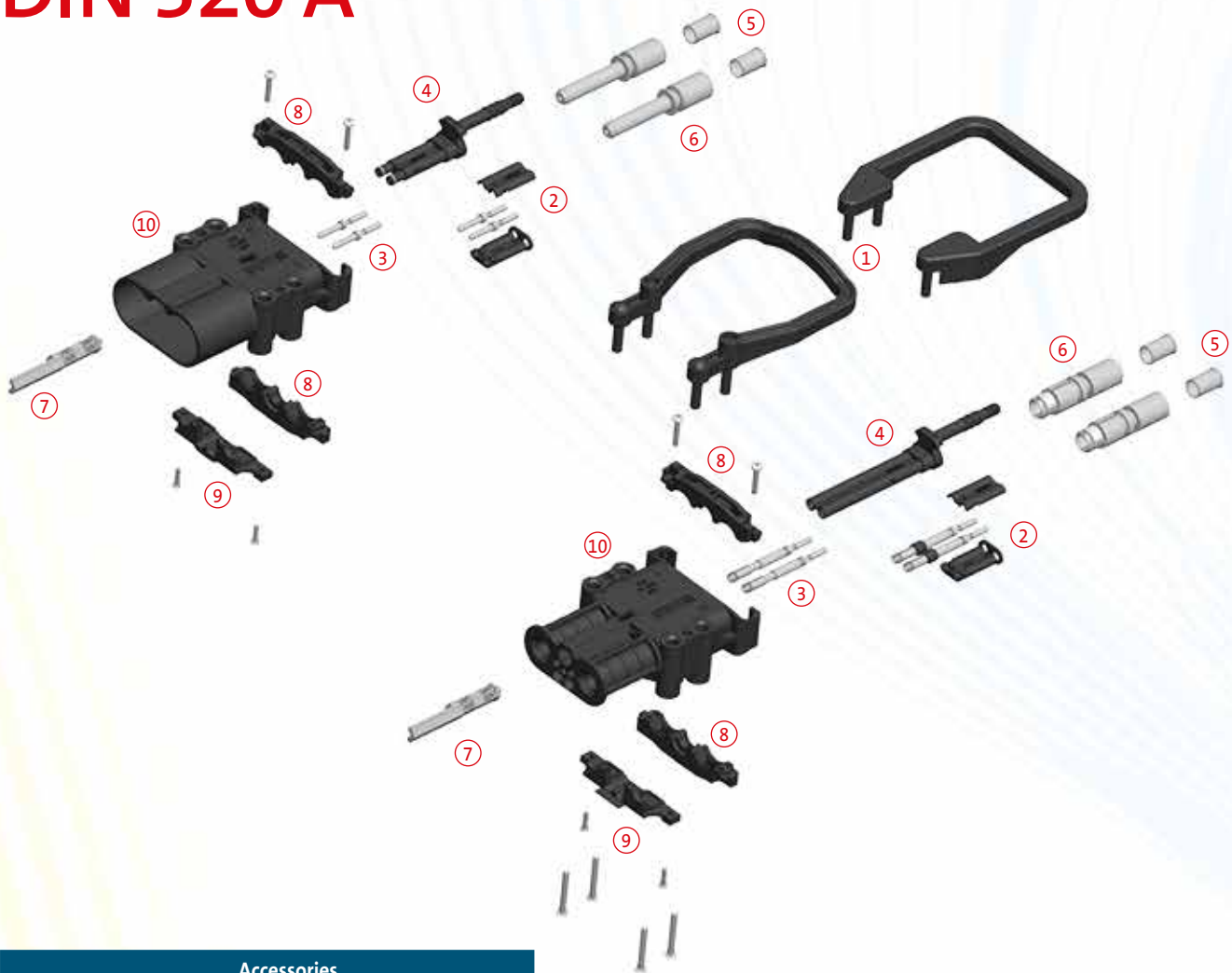

Accessories

	EM160320ST	Shock resistant handle 160/320 A
①	EM160320AR	Acid-proof handle 160/320 A
	EM160320STP	Shock resistant flat handle 160/320 A
	EM160320ARP	Acid-proof flat handle 160/320 A
	EXS160320PRST	2 primary Aux. Contacts for plug 160/320 A
②	EXP160320PRST	2 primary Aux. Contacts for socket 160/320 A
	EXS160320PRAR	2 primary Aux. Contacts for acid-proof plug 160/320 A
	EXP160320PRAR	2 primary Aux. Contacts for acid-proof socket 160/320 A
③	EXS320SEC	2 secondary Aux. Contacts for plug 160/320 A
	EXP320SEC	2 secondary Aux. Contacts for socket 160/320 A
④	EAIRTUBE320S	Air tube for plug 160/320 A
	EAIRTUBE320P	Air tube for socket 160/320 A
⑤	ERID70-35	Reduction bushing 70-35mm ²

Spare parts

⑥	EGPP-S320	2 Main Contacts for plug 160/320 A
	EGPP-P320	2 Main Contacts for socket 160/320 A
	E29304	Grey coding pin 160/320 A
⑦	E29367	Yellow coding pin 160/320 A
	E29366	Green coding pin 160/320 A

Part numbers

Part numbers are so composed:

XXXX 320 XX X

ESBC = plug
 EPBC = socket
 EKPM = socket + handle
 ST=shock resistant
 AR=Acid-proof

Add "KIT" at the end of the part number to order the set including 100 not bagged pieces.

- 1 = grey coding pin for wet batteries
- 2 = yellow universal coding pin
- 3 = green pin for dry or gel batteries

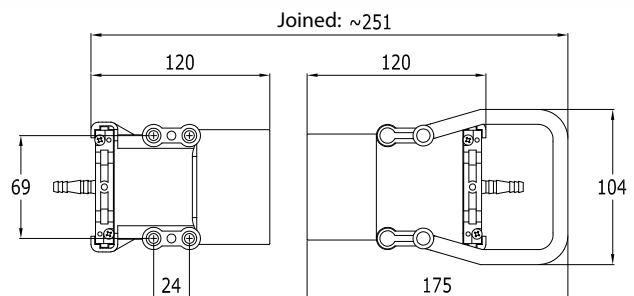

Height with mounted standard handle: 64 mm.
 Height with mounted flat handle: 48 mm.

Connectors Europe Series

DIN 320 A - 95



Accessories

	EM160320ST	Shock resistant handle 160/320 A
①	EM160320AR	Acid-proof handle 160/320 A
	EM160320STP	Shock resistant flat handle 160/320 A
	EM160320ARP	Acid-proof flat handle 160/320 A
	EXS160320PRST	2 primary Aux. Contacts for plug 160/320 A
②	EXP160320PRST	2 primary Aux. Contacts for socket 160/320 A
	EXS160320PRAR	2 primary Aux. Contacts for acid-proof plug 160/320 A
	EXP160320PRAR	2 primary Aux. Contacts for acid-proof socket 160/320 A
③	EXS320SEC	2 secondary Aux. Contacts for plug 160/320 A
	EXP320SEC	2 secondary Aux. Contacts for socket 160/320 A
④	EAIRTUBE320S	Air tube for plug 160/320 A
	EAIRTUBE320P	Air tube for socket 160/320 A
⑤	ERID70-35	Reduction bushing 70-35mm ²

Spare parts

⑥	EGPP-S320-95	2 Main contacts 95 sqmm. for plug 320 A
	EGPP-P320-95	2 Main contacts 95 sqmm. for socket 320 A
	E29304	Grey coding pin 160/320 A
⑦	E29367	Yellow coding pin 160/320 A
	E29366	Green coding pin 160/320 A

Part numbers

Part numbers are so composed:

XXXX 320 XX X-95

Add "KIT" in the indicated position to order the set including 100 not bagged pieces

ESBC = plug
 EPBC = socket
 EKPM = socket + handle
 ST=shock resistant
 AR=Acid-proof

1 = grey coding pin for wet batteries
 2 = yellow universal coding pin
 3 = green pin for dry or gel batteries

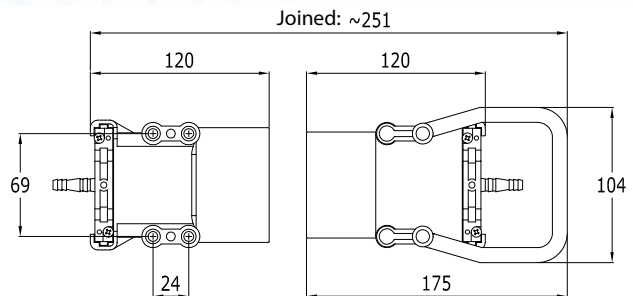

Height with mounted standard handle: 64 mm.
 Height with mounted flat handle: 48 mm.

For your safety

DIN Europe Series connectors are in accordance with the following Directives and Norms:

2006/42/CE	Machine Directive
2014/35/UE	Low Voltage
2011/65/UE	RoHS Directive
1907/2006	REACH Rules
DIN VDE 0623-589	Norm defining unified dimensions
EN 1175-1	Standardized European Norm

They are warranted by our CE Certificate, available on request, where it's declared that the product is manufactured by Ravioli according with precise and acknowledged Safety Norms, and with the quality standard stated in its Quality Management System UNI EN ISO9001-2008.



For people and environment respect

Ravioli products are manufactured in the respect of people and environment, according to the standards which are stated in our Code of Ethical Behaviour. They are realized to strengthen workers' safety and they are free from damaging substances to the environment.

Assembly and maintenance instructions

The installation of twin connectors Europe Series can only be performed by trained personnel following the current safety norms. Before wiring, it's compulsory turn out the voltage and have the machine in a condition of safety.

ATTENTION: Contact with the conductors can result in serious injury from electrical shock and electrocution.

For correct installation, environment operative temperature must be included between -20°C and +90°C.

Connectors are not suitable for any applications in potentially explosive areas.

Protect yourself suitably against eventual acid.

Do not use any oil, grease or solvent.

Connectors are lubricated with a special grease; we recommend to use no different grease.

Connections must be duly carried out, according with the machine electrical scheme.

After installation, it is obligatory to verify that the coding pin is suitable for the battery you have to use, and that the voltage indicated on the pin is the same established for the machine and for the battery charger; it is obligatory to verify the correct functioning of the connector, the machine and the battery charger.

Assembly instructions:

- Strip wires 20 mm. for main contacts (6) and 10 mm. for auxiliary contacts (2 and/or 3).
- Insert wire into contact crimp barrel till wire bottoms in barrel.
- Crimp through suitable tool. For information about crimping please contact our company.
- If you are using air system, connect the air tube into the fitting for air in-let (4).
- Insert main contacts (6) into the contacts keeper (10), using caution to respect the polarity indicated on the housing. Insert primary auxiliary contacts (2) into proper air adapter, having the two halves closed, and position them in their proper keeper (10). Insert the secondary auxiliary contacts (3) into their keeper (10). If using the optional air system, the air tube (4) must be inserted into its keeper (10) in place of the primary auxiliary contacts (2); in this case only secondary auxiliary contacts (3) will be used; they must be mounted before positioning the air tube (4). Secure all the contacts and the optional air tube (4) into the housing (10) by using the clamping plate (9) in the keeper in one side of the housing (10). Verify that all main and auxiliary contacts and the optional air tube are steadily locked by the clamping plate (9); secure the clamping plate (9) using the provided screws. For black, shock resistant models, tighten the screws with torque 1Nm. For grey, acid-proof models, tighten them with torque 0,6 Nm.
- Mount the cable clamp (8), which is composed by two halves, by tightening the two provided screws with torque 1Nm for the black, shock resistant models, or with torque 0,6 Nm for the grey, acid-proof models. If auxiliary contacts (2 and/or 3) are used, replace one half of the cable clamp (8) with the half suitable for the plastic screw for auxiliary cables clamping, which is properly supplied in the bag containing the auxiliary contacts.
- Verify that the coding pin (7) is correct according to the type of battery you will use (wet, dry or universal). Insert the coding pin (7) observing that the proper battery voltage is displayed in the housing (10) window.
- Mount the optional handle (1) with torque between 1,20 Nm and 1,40 Nm.

Maintenance:

- Verify that connectors match correctly.
- Verify that connectors are entire and that they do not present any faulty parts.
- Should there be any faulty parts, replace them.
- Verify that main contacts cables are locked by the cable clamp.

RAVIOLI S.p.a. declines any responsibility for damages deriving from incorrect installation or improper use of the product.

All information described in this document are confidential and cannot be handled nor modified without Ravioli S.p.a. authorization.

All the pictures which are shown in this catalogue are illustrative and the data can be modified without notice; therefore they cannot be used in terms of contract.

Ravioli S.p.A.
Via Passo Pordoi, 4 - 20139 Milan, Italy
Tel. +39 02 53.63.01 - Fax +39 02 53.63.05
E-mail: raviolispa@raviolispa.com - www.raviolispa.com

