

# 8.2



 **ravioli**

**CSQ**  
ISO 9001  
RAVI 9105

**Twin Connectors with Air Supply System *Air-tech***

# Twin Connectors

## EUROPE Series 80 - 160 - 320A

### with Air Supply System *Air-tech*

#### Main features

These connectors are suitable for linking electrical motors, batteries and battery chargers for lift trucks and electric vehicles up to each other.

Each model is made up of a plug and a socket different from each other.

The range includes three models:

80A: for 16 or 25 mm<sup>2</sup> insulated cable

160A: for 25, 35, or 50 mm<sup>2</sup> insulated cable

320A: for 50, or 70 mm<sup>2</sup> insulated cable

All types are prepared for the use of reducing bushings depending on the diameter of cable used.

The main contacts are in silver-plated electrolytic copper.

As laid down by the Norms:

- the connectors are supplied with a coding pin for operating voltage which ensures that only same voltage plugs and sockets can be connected.

The codified values are 24-36-48-72-80-96V cc.

- standard equipment includes a cable clamp at the end of the joined plug and socket, which guarantees protection degree IP23.
- all electrical parts are protected against accidental contact.

In addition, two auxiliary contacts featuring maximum 20A continuous duty with advance opening compared to the main contacts can be mounted.

#### Why EURO - Connectors with Air Supply System

RAVIOLI's EURO-Connectors have CE markings and are in conformity with the following Norms:

- The Norm DIN 43589 parts 1 and 2, which defines unified distances between centres and unified dimensions.
- Recommendations FEM 4007a and 4007b
- EEC European Community Directive 86/663 Add.C
- Standardised European Norm EN1175-1
- EEC European Directive 73/23 - Low Voltage

Using EUROPE Series Connectors, RAVIOLI customers know that they are in conformity with the CEE Norms.

Furthermore, in some types of traction battery a mixing of electrolyte through air is required in order to improve the life of the battery itself.

Therefore, connectors are provided with a system including two small pipes, one for the socket and one for the plug, for transportation of air between battery charger and battery.

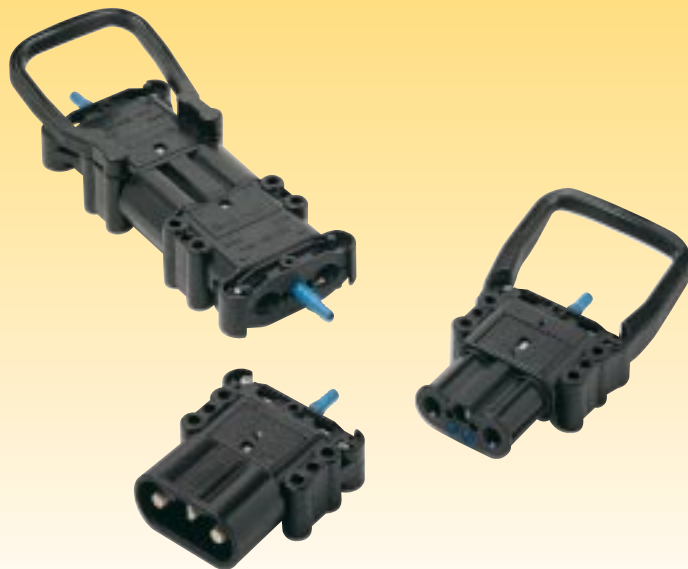

#### Other Features

Maximum operating voltage 150V cc

Temperature range -20°C + 90°C

Mechanical life (connecting-disconnecting manoeuvres) > 10<sup>6</sup> op.

The moulded housing is made of material with high dielectric and mechanical resistance, resistant to both bases and acids normally found in batteries.

Possibility of soldering or crimping the cables in the contacts, with suitable tools.



## Dimensions

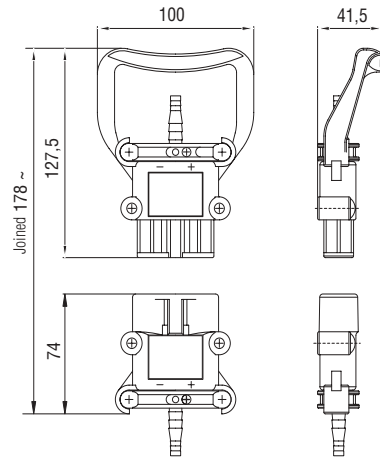

80 A

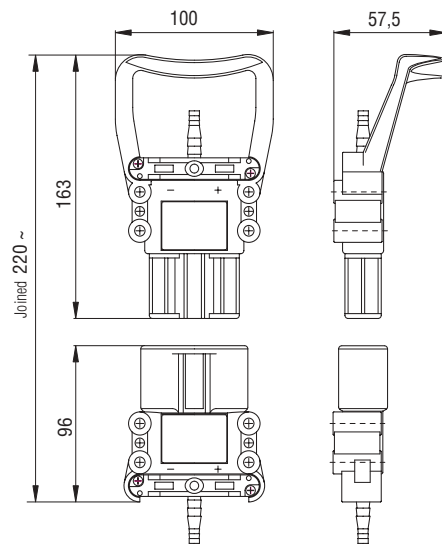

160 A

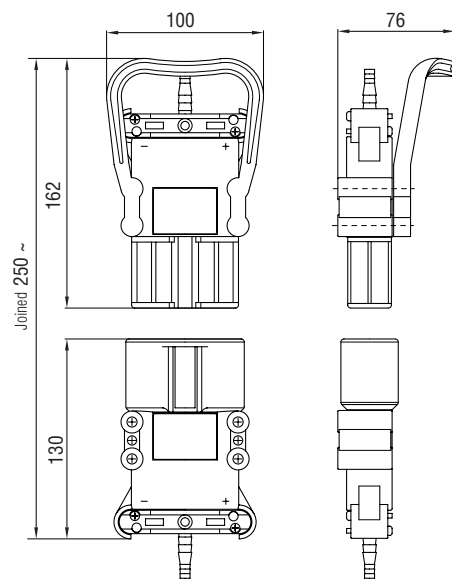

320 A

## Types and Codes

The Europe Series of twin connectors featuring the **Air-tech System**, as presented in this catalogue, are supplied dismantled and complete with all accessories required for assembly, including air pipes.

		n° cat	Codice
80A	16/25 mm <sup>2</sup> plug - complete kit with air	231	E SBC80-A
	16/25 mm <sup>2</sup> socket with handle - complete kit with air	235	E PBC80MA
	Male auxiliary contacts (2 pc.)	237	E XS80-A
	Female auxiliary contacts (2 pc.)	238	E XP80-A
160A	35/50 mm <sup>2</sup> plug - complete kit with air	531	E SBC160-A
	35/50 mm <sup>2</sup> socket with handle - complete kit with air	535	E PBC160MA
	Male auxiliary contacts (2 pc.)	537	E XS160-A
	Female auxiliary contacts (2 pc.)	538	E XP160-A
320A	50/70 mm <sup>2</sup> plug - complete kit with air	831	E SBC320-A
	50/70 mm <sup>2</sup> socket - complete kit with air	833	E PBC320-A
	Handle	839	E M160320A
	Male auxiliary contacts (2 pc.)	837	E XS320-A
	Female auxiliary contacts (2 pc.)	838	E XP320-A

# Assembling of twin connectors

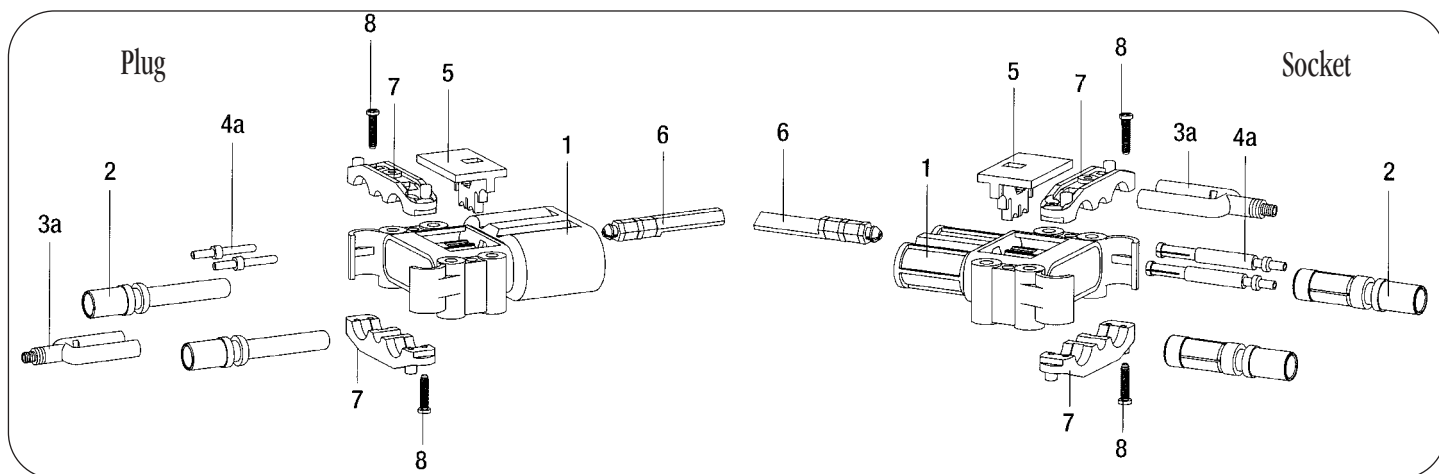

## To assemble:

1. Insert main contacts (2) in insulating casing (1)  
**WARNING:** polarity of connections must be respected!
2. Insert any auxiliary contacts (4a)
3. Insert pipe for transportation of air (3a)
4. Press the Logo (5) into position in the insulating casing (1). By so doing the position of the contacts in the casing of the connector will remain fixed.
5. Insert coding pin (6) in the casing of the connector (1) from the front. By so doing, it is possible to read the desired operating voltage through inspection window.
6. Place the cable clamp (7) above the connections, using the screws provided (8).  
**WARNING:** tighten the screws carefully to avoid damaging to the isolation of the wires.

The RAVIOLI Europe Series of twin connectors featuring the Air-Tech System can also be supplied with auxiliary contacts.

## Connecting the wires

Remove insulating material from wire endings using a suitable wire-stripping tool.  
 Ensure that all non-conducting plastic is removed before introducing the wire into the jack.  
 The following lengths of bare wire must be respected:

Wire lengths	80A	160A	320A
Main contacts	18 mm	20 mm	20/25 mm
Auxiliary contacts	7,5 mm	7,5 mm	7,5 mm

It is advised to use the wire sections recommended as well as any reducing bushings. In the event of crimping suitable tools should be used.

**WARNING:** incorrect crimping may lead over-heating, which may in turn cause damage to the insulating casing of the connector.

Among the Ravioli connectors the EUROPE series are completed by:



Please see our catalogue n° 8