



 **ravioli**

**CSQ**  
ISO 9001  
RAVI 9105

**D.C. Contactors LOGO Series - TL40**

# D.C. Contactors

## LOGO Series - TL40

### 220A

### Main features of the range

The new range of LOGO series type TL40 contactors, which are very powerful, has been designed in accordance with the safety requirements as set out in the EUROPEAN DIRECTIVE CEE 89/392 as well as with Norms CEI EN 60947-4-1 and EN 1175-1.

The products included in the range are suitable for the traction and material handling sectors using direct current and can be applied to lift trucks, industrial cleaning machines, various services on board ships and boats as well as to road and rail transport vehicles.

### Coils

The d.c. coils feature terminals with 6mm double connections. Standard duty is in intermittent mode (50%). Maximum working time is 15 mins (temporary duty).

Normalised voltages: 12 - 24 - 36 - 48 - 72 - 80 - 96V.

The following are available: reduced consumption coils for continuous duty - **option P**.

### Main contacts

These contactors have double breaking contacts, in Ag-CdO special alloy, resistant to arc and suitable for heavy duty. The contacts are also available as spare parts.

### Further options

#### Option M - magnetic blowouts

TL40M contactors featuring permanent magnets are recommended for voltages  $\geq 48V$  dc.

In this case the polarities indicated on the cover must be respected.

#### Option V - dust protection

Closed contact housings can be applied to protect the contactor from oil splashes and dust.

This option can not be used on contactor types with permanent magnets.

#### Option A - auxiliary contacts

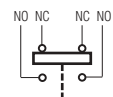

A microswitch of INO+INC auxiliary contacts can be supplied mounted on the TL40 types of contactors.

Operating current (resistive load) 5A-24Vcc



### Codes for placing orders

The product code is composed as follows:

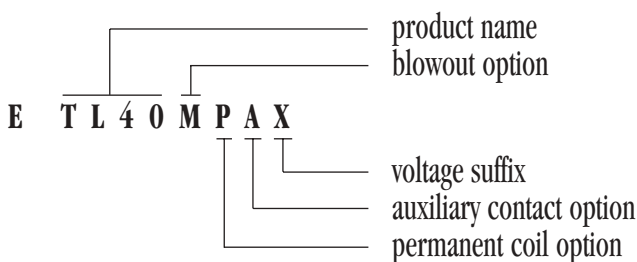

The numeric suffix identifying voltage is as follows:

Voltage (V)	12	24	36	48	72	80	96
Suffix	1	2	3	4	7	8	9

Recommended working positions:  
either horizontal or vertical with poles pointing upwards.

# Single Pole Contactors Type TL40

LOGO series single pole contactors type TL40 are available in the following versions:

- 50% intermittent coil
- 100% intermittent-permanent coil (option P)
- application of magnetic blowouts (option M)
- application of dust protection (option V)
- application of auxiliary contacts (option A)



## Types and Codes

Type	Code
TL40 50% int.	<b>E TL40</b>
TL40 50% int. and magnets	<b>E TL40M</b>
TL40 100% int.	<b>E TL40P</b>
TL40 100% int. and magnets	<b>E TL40MP</b>

The suffix A is to be added to these codes when the mounted auxiliary contact is required.

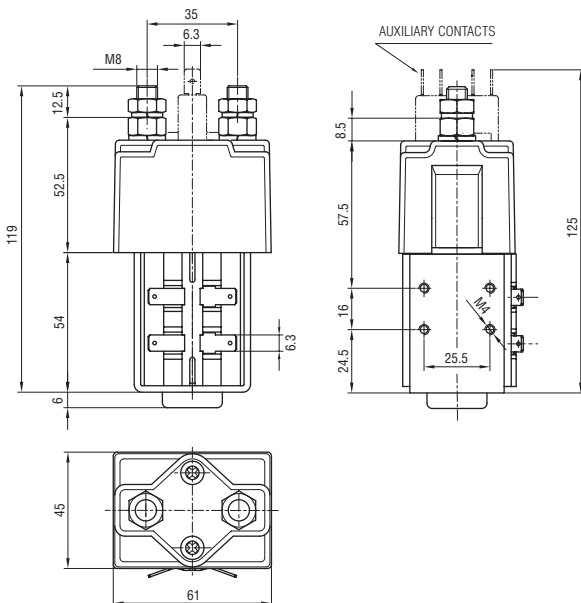

## PERFORMANCES

Contactor		TL40	TL40M	TL40P
Nominal operating current at 50% intermittent, 300 op/h	$I_e$	220A	220A	220A
Thermal current rating	$I_{th}$	150A	150A	150A
Nominal voltage	$U_e$	24V	48V	24V
Breaking capacity with 15 ms time constant		1000A	1000A	1000A
Category of usage		DC5	DC5	DC5
Working voltage limits		0,7-1,1Vn	0,7-1,1Vn	0,8-1,1Vn
Coil power dissipation		35W	35W	20W
Manoeuvre time	pull-in time	$\leq 30ms$	$\leq 30ms$	$\leq 30ms$
	drop-out time	$\leq 10ms$	$\leq 10ms$	$\leq 10ms$
Max clamps torque		60 kgcm	60 kgcm	60 kgcm
Mechanical life	op.n.	$3 \times 10^6$	$3 \times 10^6$	$3 \times 10^6$
Contact material		AgCdO	AgCdO	AgCdO
Main contacts		1NO	1NO	1NO

# D.C. Motor Reversers COMBI type TLD48

## Main Features

The COMBI type TLD48 motor reversers includes two single pole contactors with 1NO 1NC contacts and internal electrical connections. The result is a compact product featuring IP50 protection degree, spade connections and terminals excluding. Standard duty is in intermittent mode (50%) with a maximum working time of 15 minutes (temporary service). **The NC contacts are not suitable for making or breaking current.**

Performance: see corresponding models TL40 and TL40M, on page 3.

The TLD48 COMBI motor reverser is available in versions with:

- 50% intermittent coil
- application of magnetic blowout (option M)
- application of dust protection (option V)
- application of two auxiliary contacts (option A)

## Correct use of the motor reverser

The used contactors have fast drop-out times (10 msec) and relatively long pull-in times (approx.30 msec).

In this way, safe reversals can be carried out without the risk of the contacts being closed at the same time.

The use of suppressor diodes, however, increases drop-out times, and therefore it is important to choose the most suitable type of suppressor (diode+resistor).

## Type and Codes

Type	Code
TLD48 50% int.	<b>E TLD48</b>
TLD48 50% int.and magnets	<b>E TLD48M</b>

The suffix A is to be added to these codes when the mounted auxiliary contact is required.

## Diagrams of functioning

The lines  represent the links supplied with the motor reverser.

